

# prolife

## **COMPRESSOR NEBULIZER**

Prolife PN Basic (BR-CN188)\* /

Prolife PN Family (BR-CN126)\*



**en**

Instruction manual

\*The abbreviated names of devices are used in the text of the instruction:  
compressor nebulizer Prolife PN Basic/Prolife PN Family

## **CONTENTS**

<b>1</b>	Introduction .....	<b>3</b>
<b>2</b>	List of symbols.....	<b>3</b>
<b>3</b>	Field of application.....	<b>4</b>
<b>4</b>	Description.....	<b>5</b>
<b>5</b>	Complete set .....	<b>6</b>
<b>6</b>	Main technical characteristics.....	<b>9</b>
<b>7</b>	Guidelines for safe operation .....	<b>11</b>
<b>8</b>	Preparation for use .....	<b>13</b>
<b>9</b>	Operation principle and procedure .....	<b>15</b>
<b>10</b>	Cleaning and disinfection .....	<b>15</b>
<b>11</b>	Maintenance .....	<b>16</b>
<b>12</b>	Troubleshooting.....	<b>17</b>
<b>13</b>	Storage, transportation and operation requirements .....	<b>17</b>
<b>14</b>	Disposal.....	<b>18</b>
<b>15</b>	Certification.....	<b>18</b>
<b>16</b>	Warranty .....	<b>22</b>

# 1 INTRODUCTION



Please read this manual carefully before operating the device.

The information contained in this document is subject to change without prior notice.

Thank you for purchasing compressor nebulizer **Prolife PN Basic/Prolife PN Family**. The properly used nebulizer will ensure reliable medical treatment for many years.

# 2 LIST OF SYMBOLS

## Symbols Meaning



The product complies with Directive 93/42/EEC on Medical Devices.



WEEE (Waste Electrical and Electronic Equipment Directive). The symbol on the product or its package means that this product does not fall under the category of domestic waste. To avoid possible damage to the environment and human health, separate such wastes from others and dispose of them in accordance with accepted standards.



Authorized Representative in the European Union.



Manufacturer.



Note/Warning.

**IP21**

Ingress protection rating. Leading digit (protection against ingress of solid foreign objects): 2 – protection against ingress of solid objects more than 12 mm in size; fingers or other objects with a maximum length of 80 mm, or solid objects. Second digit (protection against vertically falling water drops): 1 – Vertically falling water drops should not impair the operation of the device.



Type-BF device.



Device class II (electric shock protection class).



Follow instructions for use.



Serial number.



Catalogue or model number.

### 3 FIELD OF APPLICATION

Compressor nebulizer **Prolife PN Basic/Prolife PN Family** is a medical device. Please use the device only under your doctor's and/or pulmonologist's direction.

The nebulizer is designed for inhalation therapy of asthma, chronic obstructive pulmonary disease (COPD) and other respiratory tract diseases. Please consult your doctor before using the nebulizer for inhalation therapy. Follow the doctor's instructions regarding a dose and schedule of a medicine inhaled administration.

Please observe safety measures when using the nebulizer. The device must be used only for its intended purpose and with the prescribed medicines; according to this manual; under the care of a doctor and in accordance with a doctor's instructions. This device is not intended for artificial lung ventilation and inhalation anesthesia.

Compressor nebulizer **Prolife PN Basic/Prolife PN Family** operates from the mains. It provides comfortable, rapid and safe treatment.

This device is suitable for all ages. Please read carefully this manual to familiarize yourself with the nebulizer features.

#### Contraindications

No known contraindications.

#### Possible abnormal reaction

No known abnormal reaction.

## Usage environment

This product is intended for use in medical facilities such as hospitals, clinics, medical offices, home use, living rooms. The device is not intended for outdoor use.

## 4 DESCRIPTION

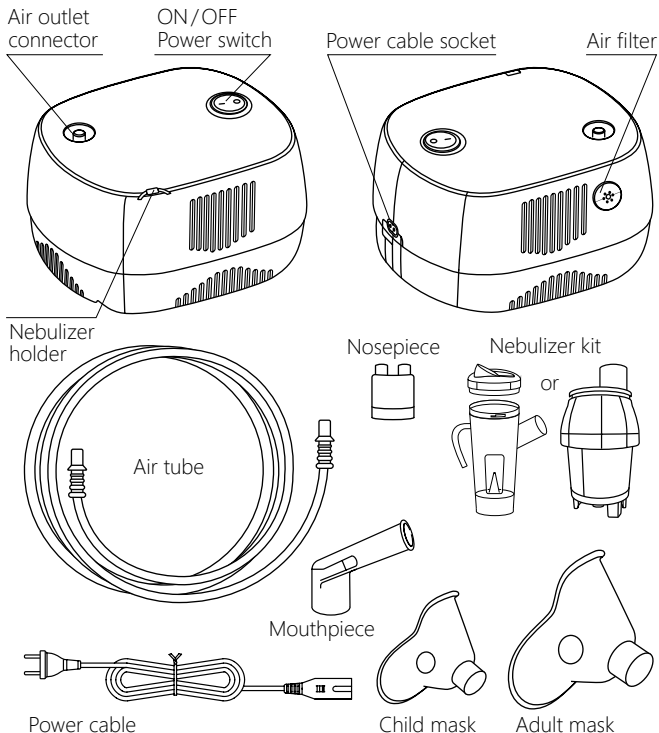

## 5 COMPLETE SET

The complete set includes the following components. If you discovered any missing components, please contact the seller immediately.

### Compressor Nebulizer Prolife PN Basic

1. Compressor (main unit)  
Prolife PN Basic.
2. Child mask Prolife PNB.
3. Adult mask Prolife PNB.
4. Nebulizer kit Prolife PNB.
  - 4.1 Nebulizer top cap.
  - 4.2 Nozzle.
  - 4.3 Nebulizer chamber.
5. 5 replaceable filters  
Prolife.
6. Air tube Prolife PNB.
7. Mouthpiece  
Prolife PNB.
8. Nosepiece Prolife PNB.
9. Power cable Prolife.
10. Instruction manual.
11. Warranty card.

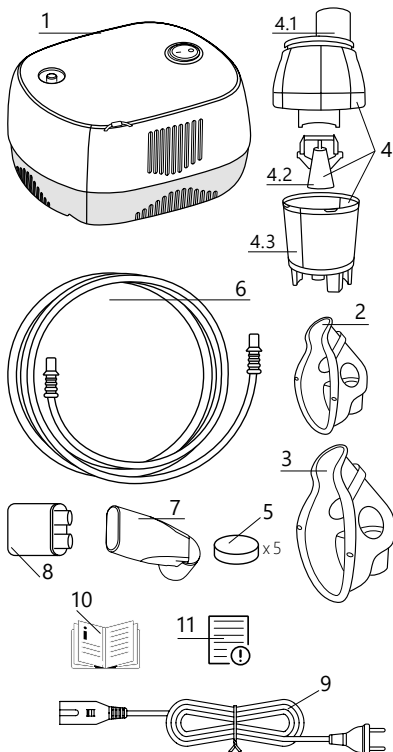

Accessories for the **Prolife PN Basic** compressor nebulizer, which can be supplied separately: **Accessory Kit Prolife PNB**.

Complete set of the Accessory Kit Prolife PNB:

1. Child mask Prolife PNB.
2. Adult mask Prolife PNB.
3. Nebulizer kit Prolife PNB.
4. Air tube Prolife PNB.
5. Mouthpiece Prolife PNB.
6. Nosepiece Prolife PNB.
7. Replaceable filter Prolife - 5 pcs.
8. Instruction manual.

### Compressor Nebulizer Prolife PN Family

1. Compressor (main unit)  
Prolife PN Family.
2. Child mask Prolife PNF.
3. Adult mask Prolife PNF.
4. Nebulizer kit  
Prolife PNF.
  - 4.1 Removable cap with  
switch of the nebula-  
zation rate and parti-  
cle size **"MIN/MAX"**.
  - 4.2 Nozzle.
  - 4.3 Nozzle lid.
  - 4.4 Nebulizer chamber.
5. 5 replaceable filters  
Prolife.
6. Air tube Prolife PNF.

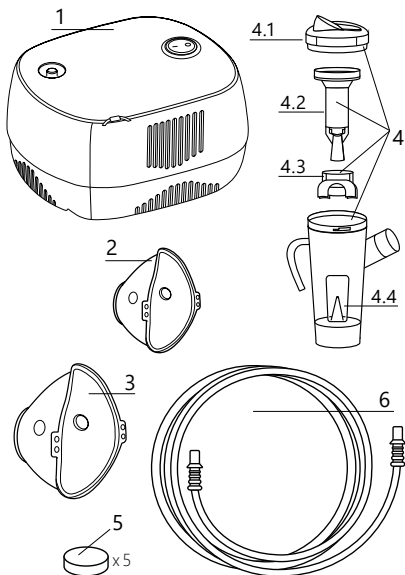

7. Mouthpiece Prolife PNF.
8. Nosepiece Prolife PN Family.
9. Power cable Prolife.
10. Instruction manual.
11. Warranty card.
12. Storage pouch

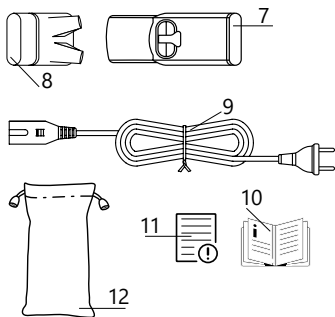

Optionally, the **Prolife PN Family** compressor nebulizer can be equipped with an additional set of accessories **Accessory Kit Prolife PNF**. This kit can also be supplied separately.

Complete set of the **Accessory Kit Prolife PNF**:

1. Child mask Prolife PNF.
2. Adult mask Prolife PNF.
3. Nebulizer kit Prolife PNF.
4. Air tube Prolife PNF.
5. Mouthpiece Prolife PNF.
6. Nosepiece Prolife PNF.
7. Instruction manual.

### Accessories and parts of the main product subject to periodic replacement\*

1. Child mask.
2. Adult mask.
3. Replaceable filter.
4. Nebulizer kit.
5. Air tube.
6. Mouthpiece.
7. Nosepiece.

\*The frequency of replacement is determined by the service life of the accessories and parts of the main product, indicated in the table in the section "Main technical characteristics".



## 6

## MAIN TECHNICAL CHARACTERISTICS

Technical characteristics	Compressor Nebulizer Prolife PN Basic with nebulizer kit Prolife PNB	Compressor Nebulizer Prolife PN Family with nebulizer kit Prolife PNF
Electrical requirements	230 VAC, 50 Hz, 0.7 A	230 VAC, 50 Hz, 0.7 A
Particle size, MMAD	$1.78 \pm 0.03 \mu\text{m}$	$2.5 \pm 0.35 \mu\text{m}$ (fast mode, nebulizer kit switch in "MAX" position) $1.65 \pm 0.05 \mu\text{m}$ (slow mode, nebulizer kit switch in "MIN" position)
Respirable fraction (0.5-5 $\mu\text{m}$ )	$93.69 \pm 1.47\%$	$78.91 \pm 3.72\%$ (fast mode, nebulizer kit switch in "MAX" position) $92.28 \pm 0.59\%$ (slow mode, nebulizer kit switch in "MIN" position)
Noise level	51.5 dBA	51.5 dBA
Power	$\leq 161 \text{ W}$	$\leq 161 \text{ W}$
Safety system	Switching off the compressor in case of overheating	Switching off the compressor in case of overheating
Weight	1340 g	1340 g
Length	162 mm	162 mm
Height	94 mm	94 mm
Width	140 mm	140 mm
Maximum pressure	241 kPa – 400 kPa (35 psi – 58 psi)	241 kPa – 400 kPa (35 psi – 58 psi)
Free flow rate	$\geq 10 \text{ l/min}$	$\geq 10 \text{ l/min}$
Operating flow rate	5 – 8 l/min	5 – 8 l/min
Nebulization rate	0.4 ml/min	0.4 ml/min (fast mode, nebulizer kit switch in "MAX" position) 0.17 ml/min (slow mode, nebulizer kit switch in "MIN" position)

Maximum and minimum volume of the nebulizer chamber	Maximum 6 ml Minimum 2 ml	Maximum 8 ml Minimum 2 ml
Storage conditions	0 °C – +40 °C; 10 – 85% RH	0 °C – +40 °C; 10 – 85% RH
Operating conditions	+5 °C – + 40 °C; 30 – 85% RH	+5 °C – + 40 °C; 30 – 85% RH
Altitude	2000 m (0 - 6500 ft) above sea level	2000 m (0 - 6500 ft) above sea level
Mode of operation	30 min ON/30 min OFF	30 min ON/30 min OFF
Service life*: – Compressor (main unit) Prolife PN Basic/Prolife PN Family – Nebulizer kit – Replaceable filter Prolife  – Child mask – Air tube – Mouthpiece – Nosepiece	7 years in case of self-used at home and 1000 working hours in case of used in medical institutions  6 months  200 working hours**  ** Note: the service life of the replaceable filter may be significantly lower than indicated due to the use of the device in a dusty environment  1 year  1 year  1 year  1 year	

\*The service life of the components may vary depending on the intensity of use. The table shows the service life when using the device for nebulization 2 ml of saline 2 times a day for 10 minutes at room temperature (23 °C). The device service life may depend on operational environment.



#### NOTE

Technical characteristics and appearance are subject to change without prior notice for purposes of improvement.

## **7** GUIDELINES FOR SAFE OPERATION



### **WARNINGS**

#### **ELECTRICAL SHOCK HAZARD**

- Protect the device against water ingress in order to prevent electrical shock.
- Do not immerse the device in liquid.
- Do not use while bathing.
- Do not touch the device that has fallen into water. Unplug immediately.
- Do not use the previously immersed in water or dropped device with damaged parts (including power cable and plug). Please contact your service center to eliminate failures.
- Do not use the device when a malfunction is detected until the device is repaired.
- Do not touch the power switch with wet hands.

#### **USAGE**

- DO NOT subject the device or its parts to strong impacts.
- Accessories should only be used by one patient; It is not recommended to use the same accessories for more than one patient to avoid cross-contamination. Purchase a separate accessory kit for each patient.
- Do not use the device in areas with presence of flammable gases, oxygen or aerosol products.
- Do not use the device if the nebulizer chamber is empty.
- Do not block the air openings. Do not place the device on a soft surface as the air openings may be blocked.
- Unplug the device from the mains before cleaning and after each use.
- Unplug the device when not in use.
- Do not turn down or shake the device during operation.
- Use only accessories recommended by the manufacturer.
- Do not disassemble or attempt to repair the device yourself.
- Do not use water in the nebulizer for inhalations.
- Clean and disinfect the nebulizer chamber, mouthpiece, air tubing, nosepiece or face mask before using them for the first time after purchase, if the device has not been used for a long time, or if the same device is being used by several persons.

- Rinse all parts after use, make sure they are properly disinfected and dried, and store them in a clean place.
- Keep out of the reach of children. The device contains small parts that can be swallowed.
- Do not cover the compressor with a blanket, towel, etc. during operation.
- Always remove any medicine residues from the cup after inhalation. Use only fresh medicine for inhalation.
- Do not use or store the device in a room with very high humidity, for instance, in a bathroom.
- This device is not intended for use by people (including children) with physical, neurological or mental disorders, or who have lack of experience and knowledge, except when these persons are supervised or instructed on the use of the device by the person responsible for their safety. It is necessary to supervise children in order to prevent games with the device, its accessories, as well as with factory package.
- The manufacturer will not be liable for any loss and damage caused by non-observance of safety regulations, improper or unintended use.
- Compressor nebulizer uses ambient air to efficiently deliver prescribed medication through the nebulizer.
- The user must be aware of the state of the environment in order to prevent dirty air from entering the compressor nebulizer.
- DO NOT use the device without a filter.
- Do not use the device in a dusty environment. Otherwise, the compressor may fail prematurely.



## **NOTE**

Clean and rinse the nebulizer before the first use of the device.

## **RISK OF ELECTRIC SHOCK**

- DO NOT disassemble the device.
- Contact qualified service personnel for service.
- Do not leave the device unattended when plugged in.
- Close supervision is necessary when the device is used by children and physically challenged people.
- Use the device only for its intended purpose as described in this manual and only with the prescribed medicines. Use the device only under a doctor's direction.
- NEVER insert any objects into openings or tubes.

## 8 PREPARATION FOR USE

Place the device on a table or other flat, stable surface. Make sure you can easily reach the "ON/OFF" switch while sitting.

### ⚠ ATTENTION

Make sure the power switch is set to "O" position.

1. Prepare the nebulizer kit. Make sure all components of the nebulizer kit are available (pic. 1 for nebulizer kit **Prolife PNB**, Prolife PNB; pic. 2 for nebulizer kit **Prolife PNF**).

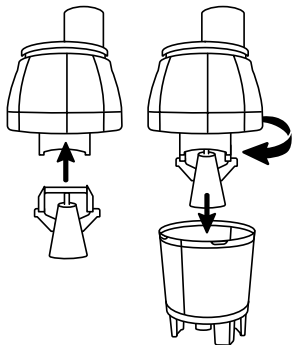

Pic. 1

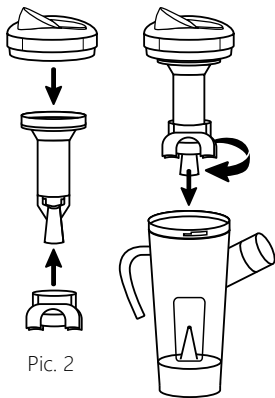

Pic. 2

- For nebulizer kit **Prolife PNB** remove the nebulizer top cap with the nozzle by turning it counterclockwise and pulling it up.
  - For nebulizer kit **Prolife PNF** remove the removable cap together with the nozzle and the nozzle cap by turning it counterclockwise and pulling it up.
2. Fill the nebulizer chamber with the inhalation solution as directed by your doctor. Please make sure that the level of the inhalation solution does not exceed the maximum (see section 6).



Pic. 3

3. **For nebulizer kit Prolife PNB, Prolife PNB** make sure the nozzle is installed in the nebulizer top cap. **For nebulizer kit Prolife PNF** make sure the nozzle lid is installed on the nozzle.
4. Put on the top cover of the nebulizer kit and close it by turning it clockwise.
5. Connect the air tube to the main unit on one side and the nebulizer kit on the other.
  - Use the mouthpiece for more intense delivery of the aerosol to the lower respiratory tract.
  - When using a mask, make sure it fits snugly around your face, covering your mouth and nose.
  - Nosepiece allows inhalation through the nose.
6. Connect the device to the mains using the Prolife power cable.

**⚠ ATTENTION**

In case of high humidity, condensation may form inside the tube. Turn on the device for two minutes before connecting the nebulizer kit to the tube, to remove condensate.

**⚠ NOTE**

Allow the device to warm up to room temperature before starting it up.

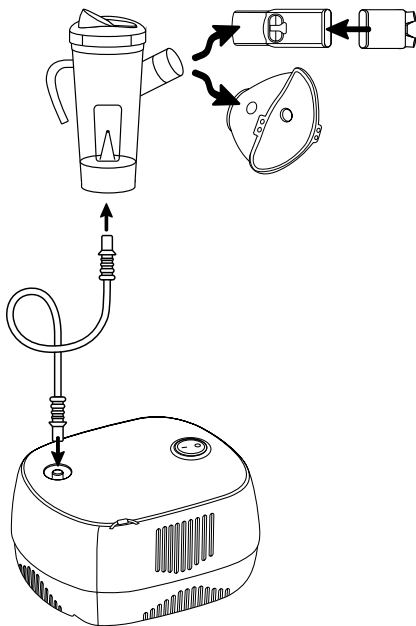

Pic. 4

## **⚠ ATTENTION**

The device is intended for irregular (periodic) operation: 30 min ON/ 30 min OFF. Failure to operate within these limits may damage the device beyond repair.

## **9 OPERATION PRINCIPLE AND PROCEDURE**

1. Turn on the device by switching the **"ON/OFF"** power switch to position **"I"** (pic. 5).
2. When spraying begins – breathe smoothly (pic. 6). During inhalation, sit straight and relaxed so that the airways are not compressed and the therapeutic effect is not impaired. Do not lie down during inhalation therapy. Stop the inhalation procedure, if you feel bad.

Pic. 5

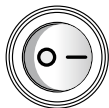

Pic. 6



**For nebulizer kit Prolife PNF** nebulization rate and particle size are switched by the **"MIN/MAX"** switch on the removable nebulizer kit cap.

## **⚠ NOTE**

If you need to make a pause during the procedure, place the nebulizer kit in the holder on the body of the main unit.

3. After completing the inhalation procedure, turn off the power by setting the switch to the **"O"** position and unplug the device.
4. Clean and dry the nebulizer and accessories before storage.

## **10 CLEANING AND DISINFECTION**

Rinsing technique (performed after each treatment or before first use).

1. Make sure the **"ON/OFF"** switch is in the **"O"** position and the device is disconnected from the power source.
2. Disconnect the air tube from the main unit and the nebulizer kit.
3. Carefully remove the nebulizer kit cap.
4. Rinse the parts of the nebulizer kit under running hot water.

5. Dry the parts with a clean towel or let them air dry completely.
6. Reassemble the nebulizer kit.

 **NOTE**

For the first time cleaning or after the unit has been stored for an extended period of time, thoroughly clean all components, including the air tube.

### **CLEANING THE COMPRESSOR (MAIN UNIT)**

Wipe the compressor daily using a soft cloth.

 **NOTE**

Any other form of cleaning or cleaning agents may damage the finish of the unit.

### **CLEANING WARNINGS**

- Check the condition of the replaceable filter, mouthpiece, nebulizer kit and other components and accessories before each use. Dirty or worn components must be replaced.
- Do not immerse the device in liquid. This may damage the device.
- Unplug the device from the mains before cleaning.
- Clean components and accessories after each use according to the instructions in this manual.
- Remove any drug residue from the nebulizer chamber after each use.
- Do not leave the air tube wet or with medication residue. This could be the cause of a bacterial infection.

## **11 MAINTENANCE**

### **FILTER REPLACEMENT**

1. The filter **MUST** be changed after approximately 200\* operating hours, or at least once a year, or when it becomes dirty (grey deposits appear).

 **\*NOTE:** the service life of the replaceable filter may be significantly lower than indicated due to the use of the device in a dusty environment.

2. To replace the filter with a new one, open compartment for a replaceable filter.
3. Replace the filter with a new one.
4. Close the replaceable filter compartment.



## **!** ATTENTION

- DO NOT wash or clean the filter.
- DO NOT operate the device without the replaceable filter.
- The replaceable filter SHALL NOT BE replaced while in use by a patient.

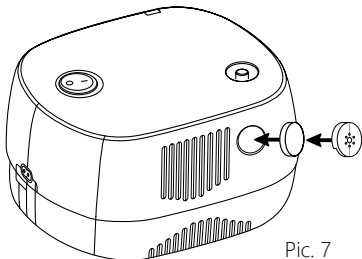

Pic. 7

## 12 TROUBLESHOOTING

Problem	Solution
The device does not turn on when switching the switch "ON/OFF"	<ol style="list-style-type: none"><li>1. Make sure the plug is firmly fitted to the wall socket.</li><li>2. Try plugging into another wall socket that is known to work.</li><li>3. Contact your service center</li></ol>
Not happening nebulization or insufficient nebulization rate	<ol style="list-style-type: none"><li>1. Make sure the air tube is properly connected to the main unit and nebulizer kit.</li><li>2. Make sure there is a solution for inhalation in the nebulizer chamber of the nebulizer kit.</li><li>3. Make sure the nebulizer outlet and air ducts are not clogged.</li><li>4. Make sure the nebulizer kit is properly assembled.</li></ol> <p>If none of the suggested solutions solved the problem, please contact to the service center</p>

## 13 STORAGE, TRANSPORTATION AND OPERATION REQUIREMENTS

- It is necessary to store the device at a temperature from 0 °C to +40 °C with a maximum relative humidity of no more than 85%.
- The device should be transported at a temperature of -20 °C to +70 °C with a maximum relative humidity of no more than 95%.
- The device should be operated at a temperature of +5 °C to +40 °C with a maximum relative humidity of no more than 85%.
- Do not expose the device to sudden temperature fluctuations.

## **ATTENTION**

After transporting or storing at low temperatures, keep the device at room temperature for at least 2 hours before switching on.

## **STORAGE PLACE**

### **NOTE**

Store the packed device in a dry place.

- Do not store the device in direct sunlight, high or low temperature or humidity.
- Keep the device out of the reach of children.

## **14 DISPOSAL**





The symbol on the product or its package means that this product does not fall under the category of domestic waste.

- Proper disposal of the device will prevent adverse environmental and human health effects.
- In order to protect the environment, the device must not be disposed of together with domestic (household) waste. Disposal shall be provided in accordance with local regulations.
- The device must be disposed of in accordance with the EU Directive 2012/19/EU WEEE (Waste Electrical and Electronic Equipment). If you have any questions, please contact the local waste disposal authority.

## **15 CERTIFICATION**

This product conforms to the provisions of the EU Medical Device Directive (93/42/EEC).

 **1\* WARNING:** Use of this equipment adjacent to or stacked with other equipment should be avoided because it could result in improper operation. If such use is necessary, this equipment and the other equipment should be observed to verify that they are operating normally.

 **2\* WARNING:** Use of accessories, transducers and cables other than those specified or provided by the manufacturer of this equipment could result in increased electromagnetic emissions or decreased electromagnetic immunity of this equipment and result in improper operation.

**3\* WARNING:** Portable RF communications equipment (including peripherals such as antenna cables and external antennas) should be used no closer than 30 cm (12 inches) to any part of the **Prolife PN Basic / Prolife PN Family**, including cables specified by the manufacturer. Otherwise, degradation of the performance of this equipment could result.

Table 1

Declaration - electromagnetic emission	
Emissions test	Compliance
RF emissions	Group 1
RF emissions CISPR 11	Class B
Harmonic emissions IEC 61000-3-2	Class A
Voltage fluctuations / flicker emissions IEC 61000-3-3	Complies

Table 2

Declaration - electromagnetic immunity		
Immunity test	IEC 60601 test level	Compliance level
Electrostatic discharge (ESD) IEC 61000-4-2	±8 kV contact ±2 kV, ±4 kV, ±8 kV, ±15 kV air	±8 kV contact ±2 kV, ±4 kV, ±8 V, ±15 kV air
Electrical fast transient/burst	± 2 kV for power supply lines	± 2 kV for power supply lines
Surge IEC 61000-4-5	± 0.5 kV, ± 1 kV line(s) to lines	± 0.5 kV, ± 1 kV line(s) to lines
Voltage dips, short interruptions and voltage variations on power supply input lines IEC 61000-4-11	0% $U_T$ ; 0.5 cycle At 0°, 45°, 90°, 135°, 180°, 225°, 270° and 315°  0% $U_T$ ; 1 cycle and 70% $U_T$ ; 25/30 cycles Single phase: at 0°  0% $U_T$ ; 250/300 cycles	0% $U_T$ ; 0.5 cycle At 0°, 45°, 90°, 135°, 180°, 225°, 270° and 315°  0% $U_T$ ; 1 cycle and 70% $U_T$ ; 25/30 cycles Single phase: at 0°  0 % $U_T$ ; 250/300 cycles
Power frequency (50/60 Hz) magnetic field IEC 61000-4-8	30 A/m	30 A/m
<b>NOTE:</b> $U_T$ is the a.c. mains voltage prior to application of the test level		

Table 3

Declaration - electromagnetic immunity		
Immunity test	IEC 60601 test level	Compliance level
Conducted RF IEC 61000-4-6	3-V 0.15 MHz to 80 MHz 6 V in ISM and amateur bands between 0.15 MHz and 80 MHz	3 V 0.15 MHz to 80 MHz 6 V in ISM and amateur bands between 0.15 MHz and 80 MHz
Radiated RF IEC 61000-4-3	10 V/m 80 MHz to 2.7 GHz	10 V/m

Table 4

Declaration - IMMUNITY to proximity fields from RF wireless communications equipment					
Immunity test	IEC60601 test level				Compliance level
	Test frequency	Modulation	Maximum power	Immunity level	
Radiated RFIEC 61000-4-3	385 MHz	**Pulse Modulation: 18 Hz	1.8 W	27 V/m	27 V/m
	450 MHz	*FM+ 5Hz deviation: 1kHz sine	0.2 W	9 V/m	9 V/m
	710 MHz 745 MHz 780 MHz	**Pulse Modulation: 18Hz	2 W	28 V/m	28 V/m
	810 MHz 870 MHz 930 MHz	**Pulse Modulation: 18Hz	2 W	28 V/m	28 V/m
	1720 MHz 1845 MHz 1970 MHz	**Pulse Modulation: 217Hz	2 W	28 V/m	28 V/m
Radiated RFIEC 61000-4-3	2450 MHz	**Pulse Modulation: 217Hz	2 W	28 V/m	28 V/m
	5240 MHz 5500 MHz 5785 MHz	**Pulse Modulation: 217Hz	0.2 W	9 V/m	9 V/m

**Note\*:** As an alternative to FM modulation, 50 % pulse modulation at 18 Hz may be used because while it does not represent actual modulation, it would be worst case.

**Note\*\*:** The carrier shall be modulated using a 50 % duty cycle square wave signal.

The tests were carried out by Montex Swiss AG, Switzerland, at the Institute of Environmental Engineering National Yang Ming Chiao Tung University, Taiwan.

### For nebulizer kit Prolife PNB

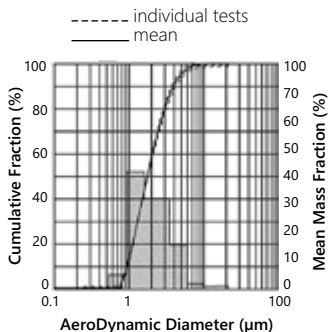

### For nebulizer kit Prolife PNF

slow mode, nebulizer kit switch in "MIN" position

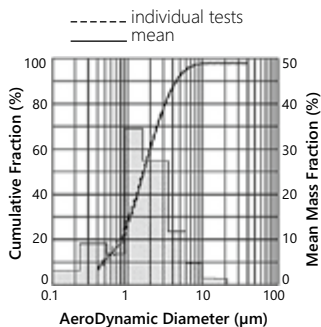

fast mode, nebulizer kit switch in "MAX" position

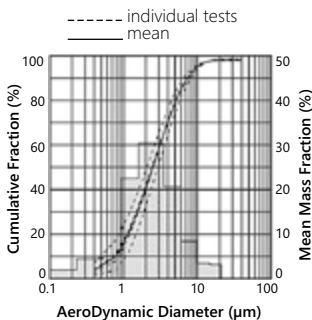

## 16 WARRANTY

Information on the warranty period for the main unit of the compressor nebulizer **Prolife PN Basic/Prolife PN Family** is indicated in the warranty card. The warranty is valid under strict observance of all operating conditions specified in this instruction manual. The warranty is only valid if there is a cashier's receipt and a warranty certificate completed by an official representative to confirm the date of sale. The warranty does not apply to consumable parts, accessories and components of the main product that are subject to periodic replacement, such as: child mask, adult mask, replaceable filters, nebulizer kit, air tube, mouthpiece, nosepiece, adapter, packaging.

### **AFTER-SALES AND FREE MAINTENANCE SERVICE IS NOT PROVIDED IN CASE OF:**

- using the device with violation of requirements specified in the instruction manual;
- damage caused by deliberate or erroneous actions of the consumer due to mishandling or negligence;
- evidence of mechanical damage, dents, cracks, chips, etc. on the device casing, opening of the casing, disassembly, unauthorized repair, ingress of moisture into the casing or effect of corrosive substances, or any other unauthorized interference, as well as in other cases of violation by the consumer of storage, cleaning, transportation and operation requirements specified in the instruction manual;
- ingress of oils, dust, insects, liquids (not intended for use with the device) and other foreign objects into the device.

### **THE WARRANTY DOES NOT COVER THE DEFECTS OR MALFUNCTION CAUSED BY:**

- normal wear and tear of the components with limited service life;
- damage to accessories that are not an integral part of the product (child mask, adult mask, replaceable filters, nebulizer kit, air tube, mouthpiece, nosepiece, adapter, packaging);
- using defective, worn out accessories and pieces;
- force majeure circumstances (accident, fire, flood, electric line fault, etc.).



### **ATTENTION**

Follow the instructions precisely to ensure reliable and long-term operation of the device.

In case of abnormal operation of the device, please contact the seller.

For repair and maintenance, please contact a specialized after-sales service.

The manufacturer reserves the right to make structural changes of the device.

**Manufacturer:**

Shenzhen Bi-Rich Medical Devices Co., Ltd.  
The 1st building of No. 10, Xinqiao GangZai Road, Xinqiao Street,  
Bao'An District, Shenzhen City, Guangdong Province, 518125,  
People's Republic of China.

**Authorized Representative in the EU:**

SUNGO Cert GmbH, Lindenstraße 48-52, 40233 Düsseldorf,  
Germany. E-mail: ec.rep@sungogroup.com

IB Prolife PN Basic & Family [en bg]

Version No: V1

Release date: 2023-07-17

CE 1639



IP21

**Prolife®** is the registered trademark by Montex Swiss AG,  
Tramstrasse 16, CH-9442, Berneck, Switzerland

prolife